

The STA 150 NDB is a self-supporting mast antenna for many kinds of fixed non-directional radio beacons. The mast does not need guys or stands. It replaces costly and spacious wire arrangements and can be installed on room limited sites.

Because of its small space requirements the antenna is also applicable for mobile and semi-mobile beacons, e. g. on board of light-vessels, offshore platforms, drilling rigs, etc.

The standard height of the antenna is 14.5 m. It can be reduced to 11.5 m upon request. (STA 115 NDB ...)

The mast antenna carries a lumped top load assembly consisting of five capacitance rods, four sloping and one vertically mounted, and one air-core coil. This inductance is housed in a watertight tube assembly. The values of the top load assembly control the frequency range of the antenna. The standard beacon antennas are made for the frequency range from 180 - 580 kHz.

The top load assembly provides a favourable voltage distribution along this quite short antenna. It also reduces the voltage values around the antenna base making the antenna more insensitive to changes in environment.

Description

Electrical

The antenna is a centre loaded mast radiator. The values of the top load assembly control the frequency range and the bandwidth of the antenna. The NDB frequency band (180-580 kHz) is splitted into four operating frequency ranges according to the bandwidth of the antenna. Different numbers of windings on the loading coil determine the different operating frequency ranges.

Mechanical

The antenna is a self-supporting mast antenna. It is made of glass-fibre reinforced plastic and consists of three different sections:

Lower Mast section
Loading Coil Assembly
Top Rod Assembly

The lower section is an 8 m (or 5 m) long conical tube. It carries the top load assembly consisting of loading coil and top rods.

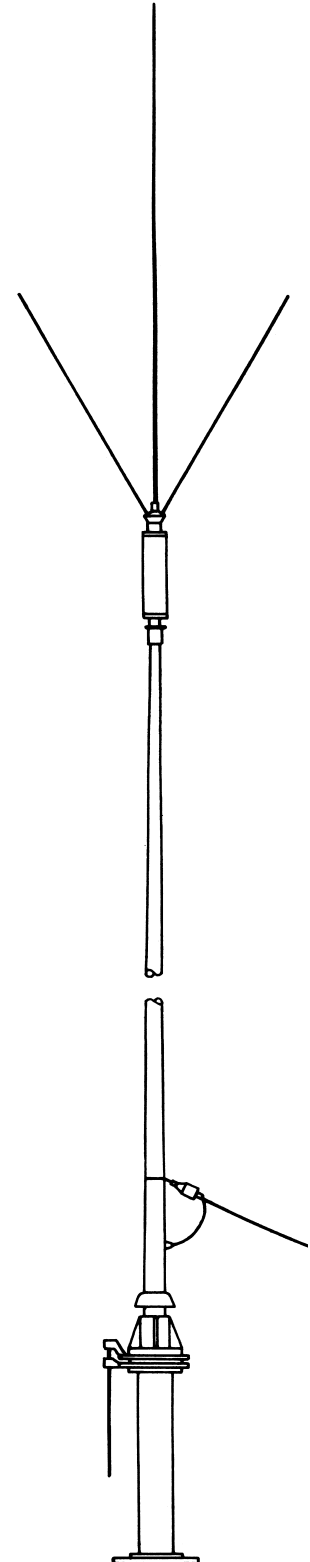

STA = Rod Antenna
E = Receiving Rod Antenna
EAU = Transformer

K = Tilt
TR = reinforced
SE = Transmit Antenna

SSB = internal feeding
SSB/E = external feeding
PM/M = dark grey (similar to RAL 7000)

NDB = Non Directional Radio Beacon

Lower Sections US 80 PM and US 80 PM/E (E for external) (or US 50 PM and US 50 PM/E)

The lower section is a conical tubular mast with radiators embedded in the mast's wall. The RF feed insulators, external and base-injected ones, are carefully designed in order to avoid instable antenna impedances. The base-injection runs concentrically into the mast tube. It is held by small supports of good dielectric constant.

On top of the lower section mast tube a joint armature carries the top load assembly. This joint fitting is connected to the embedded radiators and serves also as the electrical connection to the load assembly.

The lower section mast tube stands on a cast aluminium base. This antenna base is fixed to tilting flanges or other stands by means of eight stainless steel bolts.

The antenna can be fed either externally, injecting the mast from the side about 120 cm above the antenna base, or internally from the bottom through the antenna base (base injection).

Base injected antennas permit direct installation above the radio room and the transmitter thus saving additional installation equipment (e.g. lead-through insulators, trunks, etc.) and providing a short way between transmitter and antenna input.

Both antenna versions, the external and the base injected, can be installed on supports with appropriate tilting devices. Special attention has been paid to the watertight design of the base injected equipment.

The internally fed arrangement offers not only the cheaper installation, but is also much more insensitive to the environment.

Loading Coil Assembly

The loading coil belongs to the top load assembly (picture 5) and is housed in a watertight construction (pos. 2). The air-core coil has a Q-factor of around 500. Spaced windings ensure excellent high voltage capability. The assembly has no inband resonance points. The standard loading coil is of quite small dimensions. It is 728 mm long and 126 mm in diameter only.
(special coil versions may have deviating dimensions)

The coil assembly is mounted on the lower mast section US 80 PM (or US 50 PM). The coil assembly bottom flange is fastened to a junction disk (pos. 7) by eight stainless steel hollow screws (pos. 10). The junction disk sits on the lower section joint armature (pos. 1) fixed by a 46 mm retaining hex nut (pos. 5, tightening torque $M = 180 \text{ Nm}$).

Top Capacitance Rods

The loading coil's top joint armature holds the top rod STA 60 HV/2 (pos. 3) and the top capacitance ring (pos. 6). The top capacitance ring being tightened to the top joint armature by a second retaining hex nut (pos. 5) is kept in the given position by means of an arresting pin (pos. 13). Four capacitance rods STA 30 D (pos. 4) are fixed to that ring. They have a metric thread on their junction armature with which they are screwed to the top capacitance ring. Additional locking screws (pos. 12) on the top capacitance ring hold the rods tight in the winding.

The antenna rods STA 60 HV/2 and STA 30 D are made of conical-shaped sturdy solid glassfibre reinforced polyester rods with the radiators concentrically embedded.

Detail A Base Injection

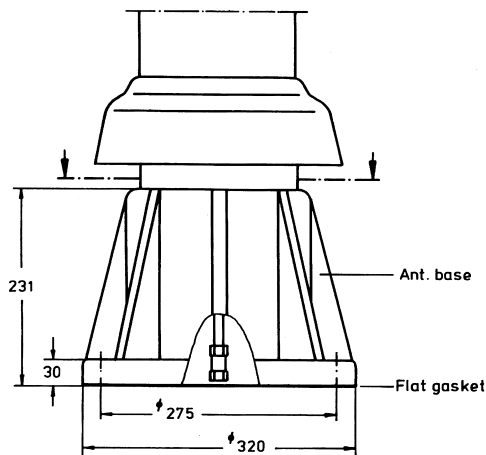

Section A-A

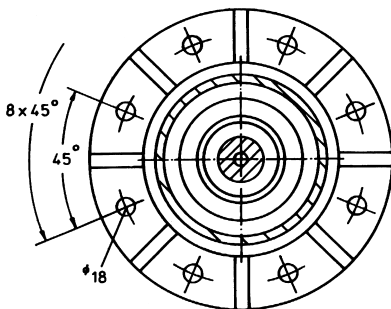

Picture 3

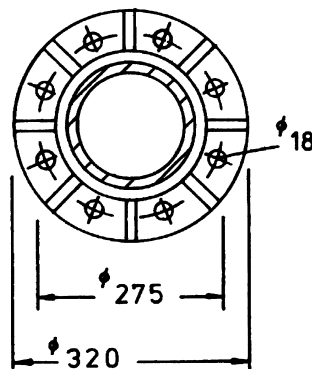

Detail B External Feeding

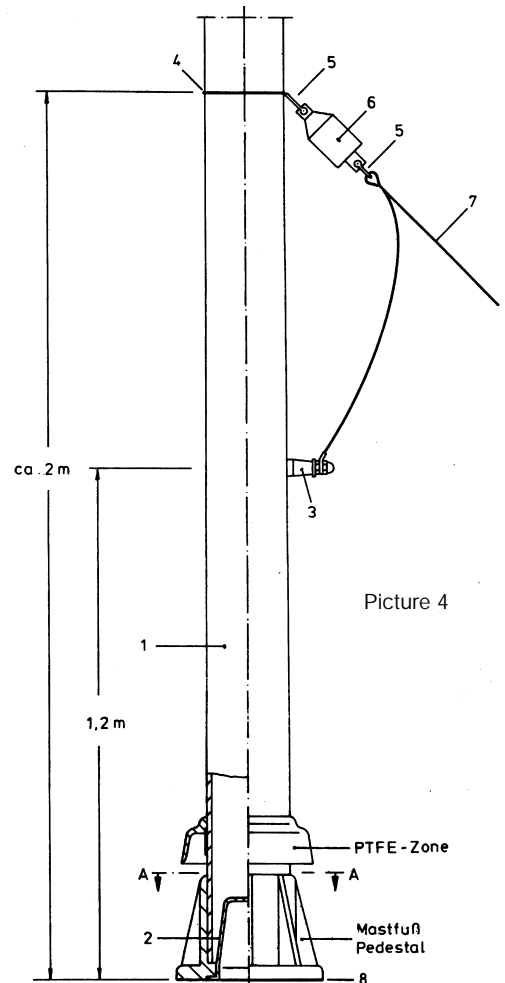

- 1 Lower section US 80 PM/E
- 2 Sealing cap
- 3 Lead-in insulator
- 4 Holding rope
- 5 Shackle
- 6 Strain insulator
- 8 Flat gasket

STA = Rod Antenna
E = Receiving Rod Antenna
EAU = Transformer

K = Tilt
TR = reinforced
SE = Transmit Antenna

SSB = internal feeding
SSB/E = external feeding
PM/M = dark grey (similar to RAL 7000)

NDB = Non Directional Radio Beacon

Specification

Frequency ranges	coil A: 250 - 320 kHz coil B: 320 - 390 kHz coil C: 390 - 450 kHz coil D: 450 - 580 kHz coil F: 180 - 290 kHz
Max. RF-load	225 Watts CW
Impedance MF	resistance: 0.5 ... 4.0 Ohm capacitance: 200 ... 500 pF
Polarization	vertical
Characteristic	omnidirectional
Construction	self-supporting mast antenna
RF injection methods	1. internal base injection 2. external lead-in ... /E
Material	mast: glassfibre reinforced, polyester antenna base: G-AlMg3Si (seawater resistant aluminium)
Colour	grey
Height	STA 150 NDB ... - 14.5 m STA 115 NDB ... - 11.5 m
Weight	STA 150 NDB approx. 80 kg STA 115 NDB approx. 50 kg
Centre of gravity of surface	4.8 m
Max. bending moment	STA 150 NDB ... 1200 daNm (at 150 km/h wind and 8 m/s ² acceleration) STA 115 NDB ... 600 daNm
Temperature	- 40° ... + 80° C
Environment	resistent to sea environment as met on board of seagoing vessels
Icing	isolation and foot impedance very little or not at all effected due to preventing protective measures
Mould growth and microbes	not effected
Termites	not effected

Mounting Instructions

The tilting device for the antenna is an indispensable accessory. It eases not only the first installation, but saves also avoidable costs later when the antenna must be laid down for maintenance (e.g. no cranes, large stages, etc.).

The erection of the antenna can be done without a crane. The tilting plate of the tilting device may be opened as much as the spindle length permits in order to screw on the base end of the lower mast section US 80 PM. This mast part can be lifted easily by one man only. After being attached to the tilting plate the antenna may be lifted by the tilting device into a horizontal or other convenient position in order to fit the loading coil and to complete the top load assembly.

The top load assembly may be installed in the same order as shown on picture 5. Special attention shall be paid to the retaining screws, pos. 5, hex nut 46 mm. They shall be screwed up with a torque wrench adjusted to 180 Nm.

Unsafe fastening could have bad consequences.

Base Injection (Internal Feeding)

The connection between the internally fed antenna and supporting pipe with tilting device is made by a knife contact assembly (please, refer to picture 6). The single parts of such a base-injected equipment are readily equipped with the corresponding components of this knife contact assembly. Upon delivery of a combination of antenna with support as well as tilting flange the attached 6 mm clamping cone does not have any function, but may be removed. Only in case of an installation of the base injected antenna without tilting device (with or without supporting pipe), this clamping cone has to be used, which means that the fitted knife contact must be dislodged. After the antenna has been assembled it should be erected slowly as the knife contact must be adjusted carefully until male and female parts meet properly. Only the male contact at the antenna shall be adjusted such that it fits the bottom of the female contact with 5 mm space. Attention shall be paid to it that the female contact at the supporting pipe may not be adjusted to avoid possible deformations. After the first adjustment the antenna shall be tilted two or three times in order to make sure the proper position of all components. When the contact assembly sits accurately, please, fix all counter screws.

Detail C

Top Load Assembly

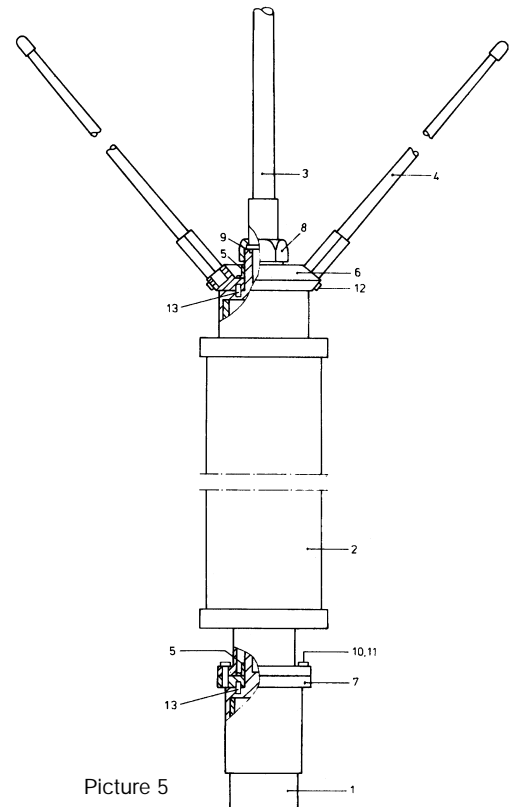

Picture 5

- 1 Lower mast section US 80 PM
- 2 Loading coil
- 3 Top rod STA 60 HV/2
- 4 Top capacitance rod
STA 30 D (4x)
- 5 Hex nut 46 mm
- 6 Capacitance ring
- 7 Junction disk
- 8 Holding nut
- 9 O-Ring
- 10 Hollow screw M 8
- 11 Washer 8.2
- 12 Locking screw
- 13 Arresting pin

Base Injection

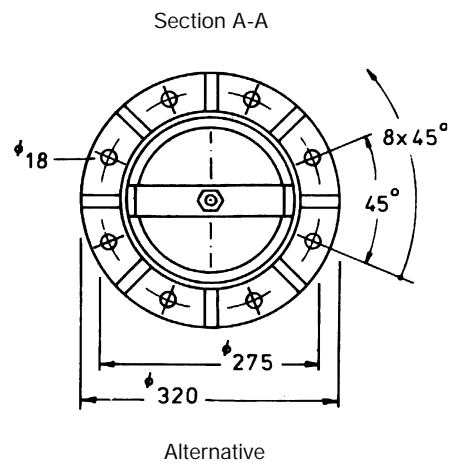
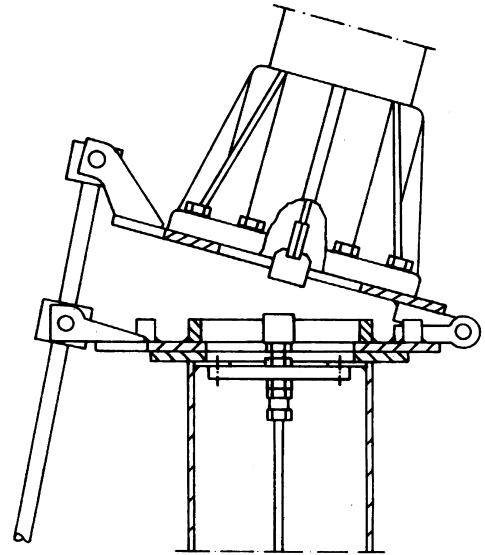
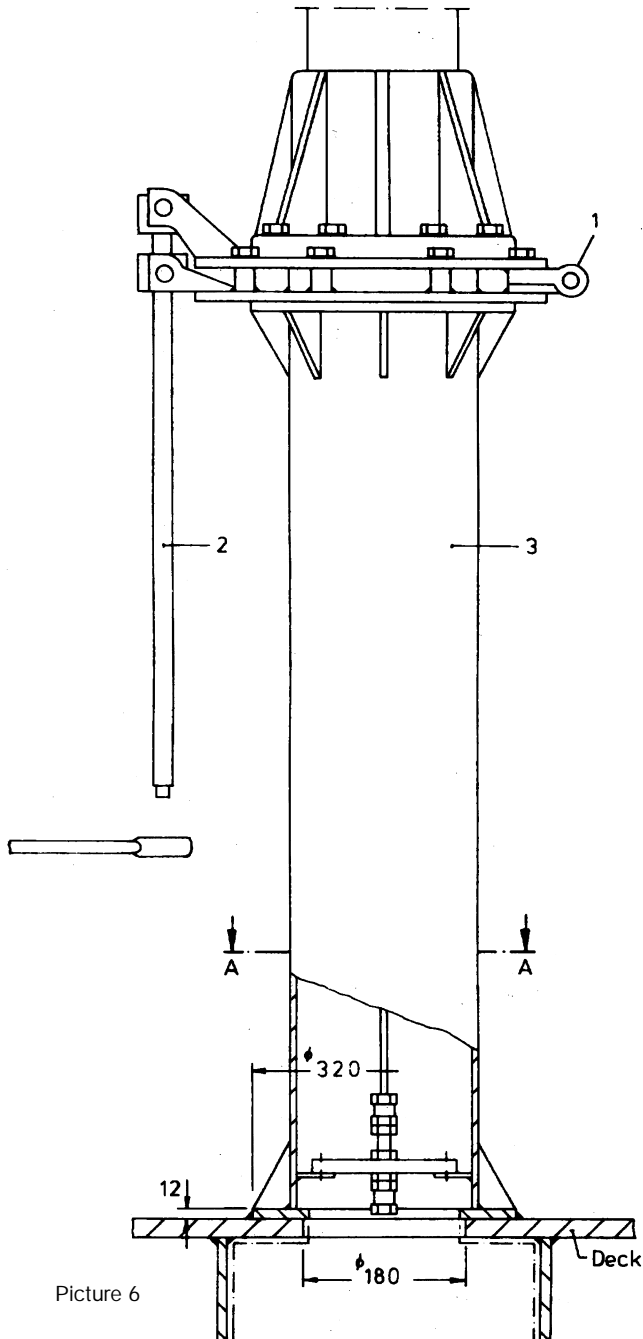

- 1 Tilting device K 8
- 2 Spindle Assembly SP/G
- 3 Supporting Pipe TR 12/K

External Feeding

Please, choose the mounting place and the tilting direction carefully. Take care - that the antenna tilts into the approximate direction of the feeder wire, if possible. Otherwise, the feeder wire had to be detached before each tilting operation.

The external feed assembly is shown on page 20 1.6. The nylon holding rope (pos. 4) with insulator (pos. 6) holds the feeder wire (pos. 7). The holding rope adjusts itself on the conical mast as the rope sling slips down until it fixes at its proper position approx. 2 m above the base.

The feeder wire shall not be tightened too much. It shall hang loose, whereby a dip of 20 cm is allowed for a 4 m long wire. The wire shall slope downwards from the mast.

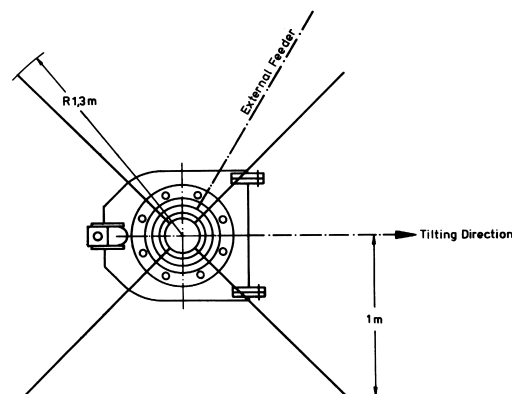

Picture 7

Maintenance

Although the antenna needs very little care, the operator should watch the antenna current from time to time. Unsteady antenna current often gives the first indication of undesired contamination of the antenna. Special attention shall be paid to the base area of the lower section US 80 PM and the loading coil. Both portions shall be washed with clear sweet water, if too much dirt has deposited. If really necessary, soft cleansers may be added to the water.

Never paint the antenna or parts of it. Today's industrial paints are based on metal containing colour pigments. Such paints will definitely reduce the antenna's performance.

Funkfeuerantennen / Radio Beacon Antenna

STA 150 NDB (STA 115 NDB)

Installation Proposal Base Injection

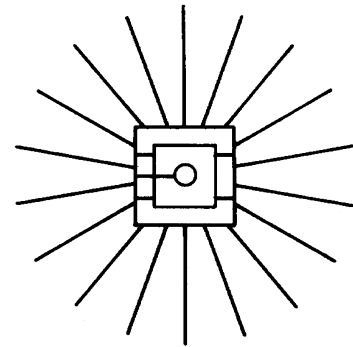
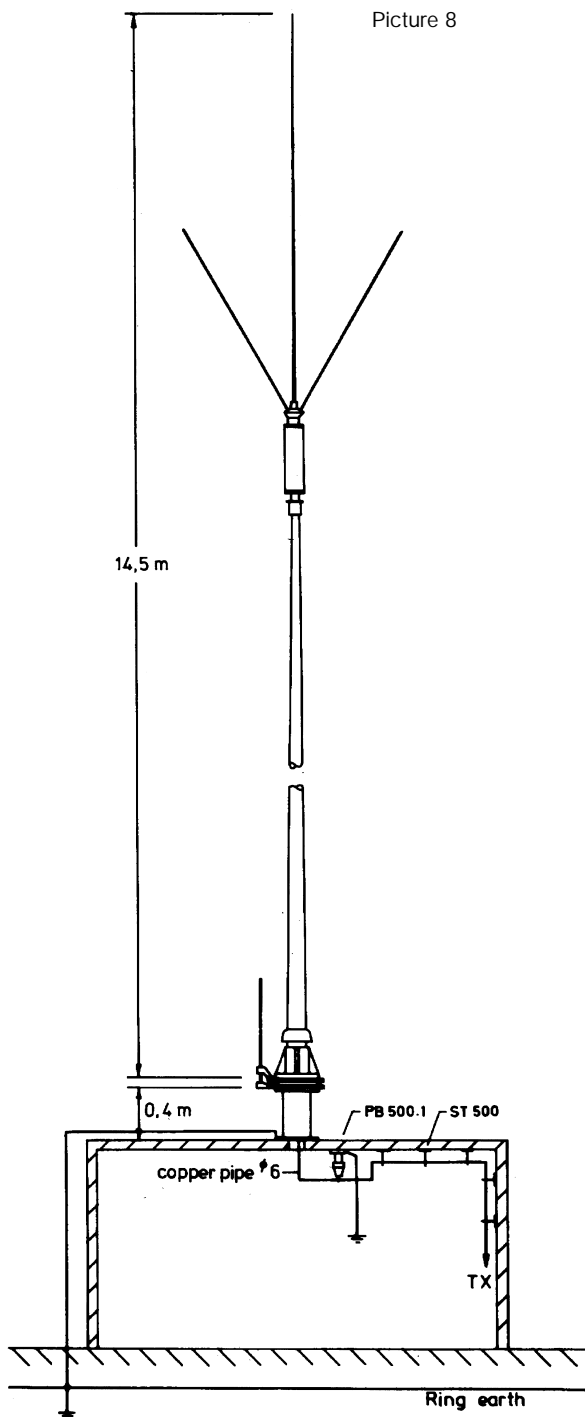

Funkfeuerantennen / Radio Beacon Antenna

STA 150 NDB (STA 115 NDB)

Installation Proposal External Feeding

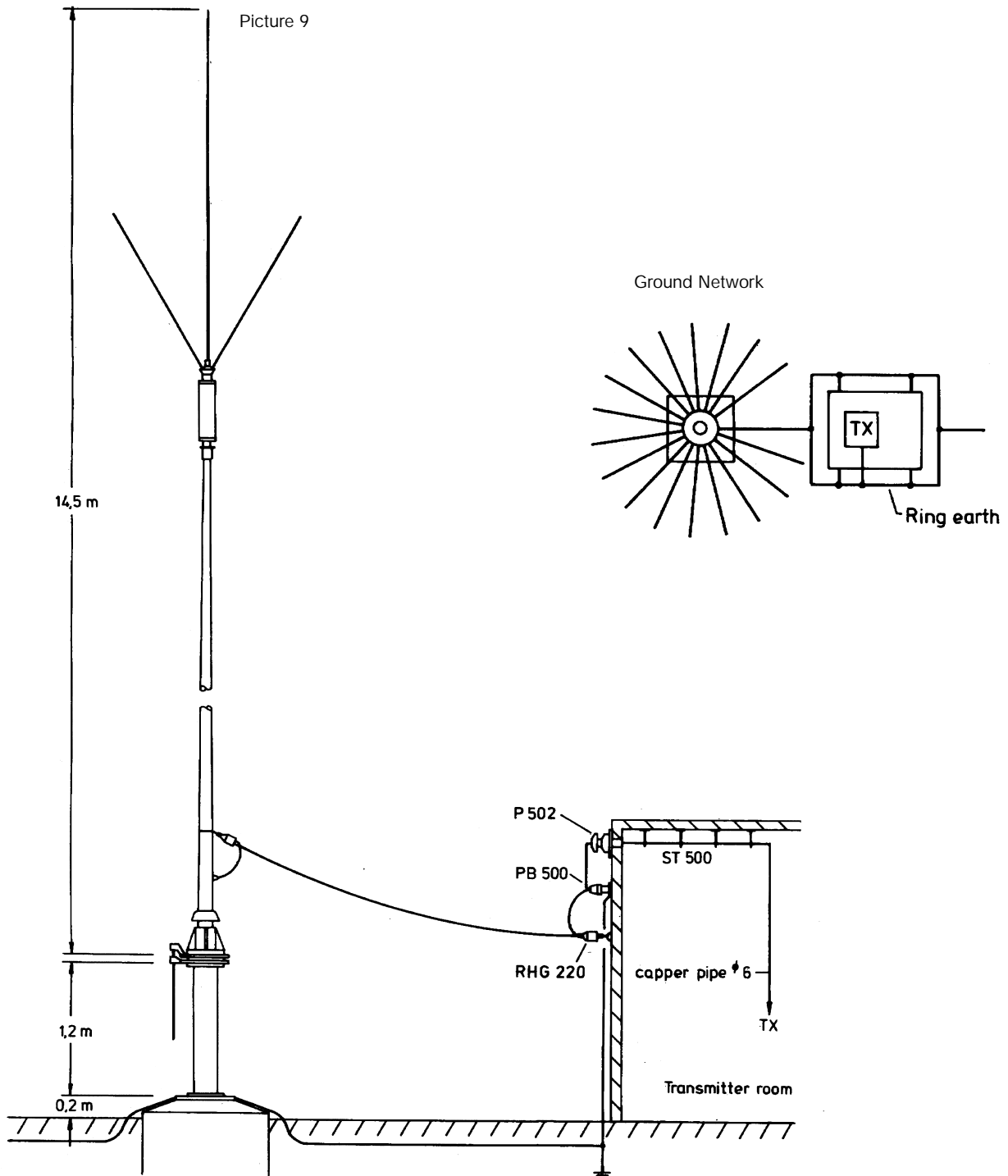

STA = Rod Antenna
E = Receiving Rod Antenna
EAU = Transformer

K = Tilt
TR = reinforced
SE = Transmit Antenna

SSB = internal feeding
SSB/E = external feeding
PM/M = dark grey (similar to RAL 7000)

NDB = Non Directional Radio Beacon

Concrete Basement for STA 150 NDB

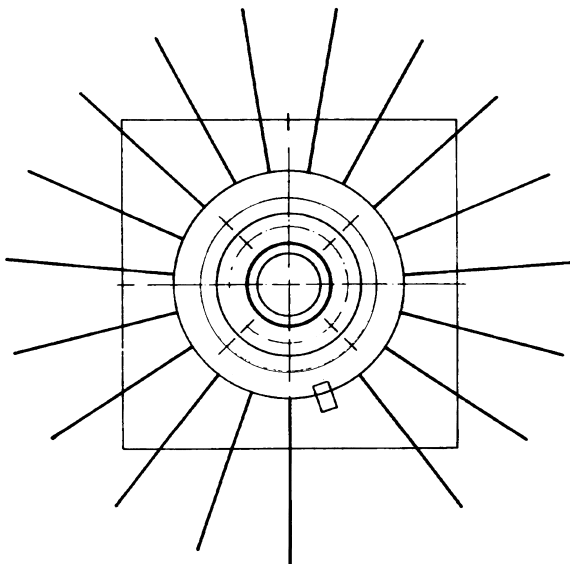
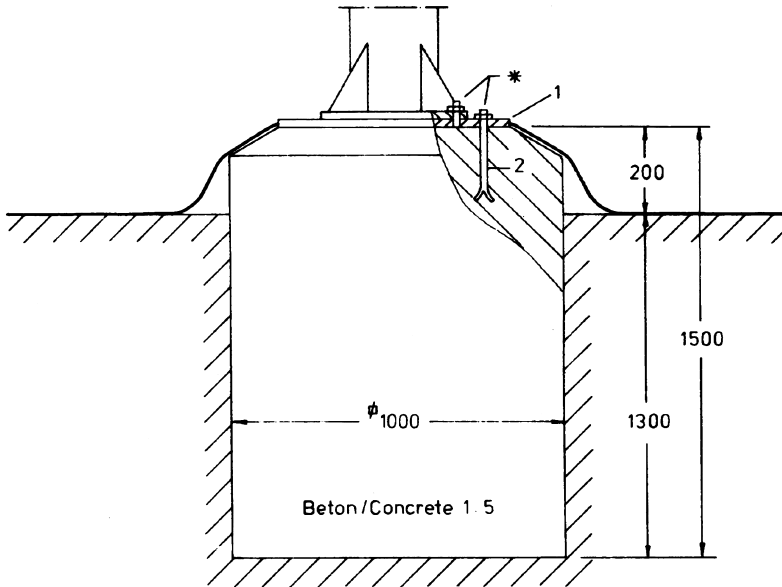

- 1 Foundation plate FP 8A
 - 2 Stone bolt M 16 x 200 - DIN 529 (8x)
 - 3 Counterpoise CP 18/15
(18 radials at 15 m each)
- Tightening torque $M_A = 160 \text{ Nm}$

STA 150 NDB ...

Standard Supplies

A) Base Injected Antenna STA 150 NDB/ ... :

1 collo (approx. 40 x 40 x 810 cm) = approx. 80 kilos =

- 1 x lower section US 80 PM with
- 1 x junction disk
- 1 x top rod STA 60 HV/2
- 4 x top capacitance rods STA 30 D
- 1 x flat gasket

1 wooden case (approx. 20 x 20 x 90 cm) = approx. 20 kilos =

containing: 1 x loading coil
1 x small material
1 x description

B) External Antenna STA 150 NDB/E/ ... :

1 collo (approx. 40 x 40 x 810 cm) = approx. 80 kilos =

- 1 x lower section US 80 PM/E with
- 1 x junction disk
- 1 x top rod STA 60 HV/2
- 4 x top capacitance rods STA 30 D
- 1 x flat gasket.

1 wooden case (approx. 20 x 20 x 90 cm) = approx. 20 kilos =

containing: 1 x loading coil
1 x holding rope with insulator
1 x feeder wire 6 m (PTFE coated)
1 x small material
1 x description

Optional Supplies

Tilting Devices + Supporting Pipes
Insulator Trunks STP 2500 resp. STP 3000 D
Insulator P 502
Insulator PB 500
Insulator RHG 220
Stand-Off Insulators ST 300 resp. ST 500
Ground Networks

STA 115 NDB ...

Reduced Height Model STA 115 NDB/E/...

(available on special request)

The height of the antenna will be modified by using a lower mast section of 5 m only instead of the standard 8 m mast. The STA 115 NDB/E is available with external feeder.

It consists of:

- 1 x lower section US 50 PM/E (5 m long)
- 1 x loading coil
- 1 x top rod STA 60 HV/2
- 4 x top capacitance rods STA 30 D

It shall be mounted on the 1.5 m high support TR 15 R/E (resp. TR 15 R/E/B) with the tilting flange K 5/E.

Further details can be taken from the data sheet STA 115 C/MF/HF/E.

Standard Supplies

1 collo (approx. 30 x 30 x 590 cm) = approx. 40 kilos =

- 1 x lower section US 50 PM/E with
- 1 x junction disk
- 1 x top rod STA 60 HV/2
- 4 x top capacitance rods STA 30 D
- 1 x flat gasket

1 wooden case (approx. 20 x 20 x 90 cm) = approx. 20 kilos =

- 1 x loading coil
- 1 x holding rope with insulator
- 1 x feeder wire 6 m (PTFE coated)
- 1 x small material
- 1 x description

Optional Supply

Please, refer to data sheet STA 115 C/MF/HF/E

Funkfeuerantennen / Radio Beacon Antenna

STA 150 NDB (STA 115 NDB)

External Feeding (Picture 4)

Pos.	Otv.	Description	Designation	Remarks
1	1	lower section	US 80 PM/E	external injection
2	1	sealing cap	06-02-56-01-13	
3	1	lead-in insulator G	00-06-06-03-00	
4	1	holding rope	D/26	
5	2	shackleAL63		
6	1	insulator	RHG 220	cpl. with shackles
7	1	litz wire	O/41	PTFE coated
8	1	flat gasket	DI/27	

List of Components

Top Load Assembly (Picture 5)

Pos.	Otv.	Description	Designation	Remarks
1	1	lower section	US 80 PM or PM/E	8 m long
2	1	loading coil	A	250 - 320 kHz resp.
			B	320 - 390 kHz resp.
			C	390 - 450 kHz resp.
			D	450 - 580 kHz
3	1	top rod	STA 60 HV/2	6 m long (sectionalized)
4	4	top capacitance rod	STA 30 D	3 m long
5	2	hex nut D/35	46 mm width	
6	1	top capacitance ring	DK 4	
7	1	junction disk	D/231	
8	1	locking nut	D/34	
9	1	O-Ring DI/9		
10	8	hollow screw	S 1/154	
11	8	spring washer	S 1/58	
12	4	locking screw	S 2/8	
13	2	arresting pin	S 2/169	

STA = Rod Antenna K = Tilt SSB = internal feeding NDB = Non Directional Radio Beacon
E = Receiving Rod Antenna TR = reinforced SSB/E = external feeding
EAU = Transformer SE = Transmit Antenna PM/M = dark grey (similar to RAL 7000)



Funkfeuerantennen / Radio Beacon Antenna

STA 150 NDB (STA 115 NDB)

Spare Parts List

Position	Designation	Order-Code
1	STA 115 NDB/E/SA	E 107-617
1	STA 115 NDB/E/SB	E 107-618
1	STA 115 NDB/E/SC	E 107-619
1	STA 115 NDB/E/SD	E 107-620
1	STA 115 NDB/E/SF	E 107-621
1	STA 150 NDB/SA	E 107-624
1	STA 150 NDB/SB	E 107-625
1	STA 150 NDB/SC	E 107-626
1	STA 150 NDB/SD	E 107-627
1	STA 150 NDB/SF	E 107-628
1	STA 150 NDB/E/SA	E 107-632
1	STA 150 NDB/E/SB	E 107-633
1	STA 150 NDB/E/SC	E 107-634
1	STA 150 NDB/E/SD	E 107-635
1	STA 150 NDB/E/SF	E 107-636
2 Lower section	US 80 PM/E	E 107-552
3 Lower mast section	US 80 PM	E 107-492
4 Top rod	STA 60 HV/2	E 107-082
5 Top capacitance rod	STA 30 D (4x)	E 107-154